

Upper Cabin Fastening

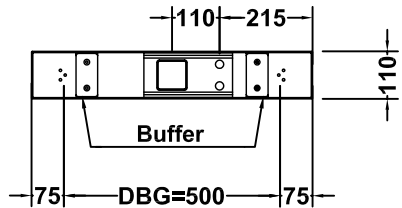

Buffer

Pillar 60x60x3
H MAX=3500 mm

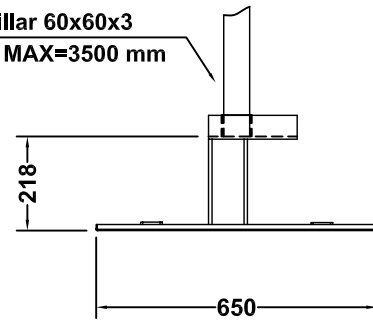

TECHNICAL DATA

LOADS	Capacity	400 Kg
	Max Cross Loads	740 Kg
	Car Weight	250 Kg
	Car Frame Weight	90 Kg
	Pulley Assembly Weight	23 Kg
Max. Speed (Instantaneous Safety Gear)		0.15 m/sec
Guide Type		Thyckness 9 mm
Nr. Ropes/Diameter		N° 2 ø 8
Guide shoe type		Sliding shoe
Pulley Diameter		ø 320 mm
Max. Ram Diameter "Pd"		ø 80 mm
Min. Pit Depth		100 mm

Draught ropes L or R assembly option

CAR FRAME TYPE 501 2:1

Page	
Date	29.02.2005
Code	16AAAM01
Edition	3,0

TECHNOUFT s.r.l.

LAVIS - TRENTO